

**NORTH CAROLINA DEPARTMENT OF HEALTH AND HUMAN SERVICES
DIVISION OF PUBLIC HEALTH
ENVIRONMENTAL HEALTH SECTION
ON-SITE WATER PROTECTION BRANCH**

INNOVATIVE WASTEWATER SYSTEM APPROVAL
--

Innovative Wastewater System Approval Number: IWWS 2002-1-R3

Issued To: AquaPoint.3 LLC
39 Tarklin Place
New Bedford, MA 02745
www.AquaPoint.com

Contact: Stephen Sedgwick
508-985-9050

For: Bioclere™ Modified Trickling Filter Systems

Approval Date: April 18, 2002
October 21, 2013 Addition of 16 Series and other Modifications
December 31, 2024 Updated for 15A NCAC 18E, Removal of Settling Tank,
and renewed for 2025
December 31, 2025 Renewed for 2026

In accordance with G.S. 130A-343 and 15A NCAC 18E, Section .1700, an application by AquaPoint for a renewal of the approval for their on-site wastewater systems utilizing the Bioclere™ Modified Trickling Filter has been reviewed and found to meet the standards of an innovative system when all of the following conditions are met.

I. General

A. Scope of this Innovative Approval

1. Bioclere™ Modified Trickling Filter pretreatment systems are designed, installed, operated and maintained to meet TS-I or TS-II effluent standards in accordance with 15A NCAC 18E .1201(a), Table XXV.
2. Operation, maintenance, and monitoring of Bioclere™ Modified Trickling Filter pretreatment systems and associated dispersal fields to ensure the treatment performance standards are met.

B. This Innovative System Approval is applicable to wastewater systems utilizing Bioclere™ Modified Trickling Filter pretreatment systems that have a design flow less than or equal to 3,000 gallons per day (gpd), and that treat the following:

1. domestic wastewater;
2. wastewater from food service facilities and meat markets; or

3. similar high strength wastewater from other commercial establishments.

Pretreatment devices must be installed prior to the Bioclere™ Modified Trickling Filter pretreatment system to reduce fats, oil and grease to less than 100 mg/l.

- C. Any site utilizing these systems shall have sufficient alkalinity to perform the proper amount of nitrification. The influent also shall not have a pH or toxins that significantly inhibit microbial growth.
- D. Chemical additives shall be provided if required for the Bioclere™ Modified Trickling Filter pretreatment system to meet the treatment performance standards.
- E. Use of Bioclere™ Modified Trickling Filter pretreatment systems that have a design flow greater than 3,000 gpd may be permitted after approval by the Department on a case-by-case basis in accordance with 15A NCAC 18E .0302(e) or in accordance with G.S. 130A-336.1.

II. System Description

The Bioclere™ Modified Trickling Filter pretreatment systems consist of the following components: a state approved septic tank; and single or multiple Bioclere™ Modified Trickling Filters with clarifier, arranged in series or parallel; and a clarifier return line to the initial septic tank. Additional treatment may be used to ensure that treatment performance standards shall be met.

III. Siting Criteria

Bioclere™ Modified Trickling Filter pretreatment systems and associated dispersal fields shall be sited and sized in accordance with 15A NCAC 18E, Section .1200 for TS-I and TS-II systems. Drip irrigation systems used with Bioclere™ Modified Trickling Filter pretreatment systems shall be sited and sized in accordance with 15A NCAC 18E .1204 and the manufacturer specific drip approval. The Bioclere™ Modified Trickling Filter pretreatment systems and associated dispersal fields shall meet all applicable horizontal setback requirements in accordance with 15A NCAC 18E, Section .0600 or .1202 and be located to prevent surface and subsurface water inflow and infiltration.

IV. System Sizing

The system sizing criteria shall be based upon the long-term acceptance rate specified in the appropriate portion of the rules or the Provisional, Innovative, or Accepted system approval for the type of dispersal system to be used.

V. Special Site Evaluation

A special site evaluation may be required based on the proposed dispersal system. Refer to 15A NCA 18E .0510.

VI. Design Criteria

- A. The Bioclere™ Modified Trickling Filter pretreatment system shall be designed in accordance with the following criteria.
1. Grease traps sized in accordance with 15A NCAC 18E .0803 shall be required for food service facilities, meat markets, and other places of business projected to generate wastewater with high levels of fats, oils, and greases.
 2. The septic tank shall be approved by the Department. The septic tank will have inlet and outlet sanitary tees.
 3. A 1½-inch clarifier return line shall be routed to the initial septic tank.
 4. For systems designed to meet TS-I standards, the clarifier return line to the initial septic tank shall operate at approximately 50 percent of the average flow to the Bioclere™ Modified Trickling Filter.
 5. For systems designed to meet TS-II standards, the clarifier return line to the initial septic tank shall operate at approximately 100 to 200 percent of the average flow to the Bioclere™ Modified Trickling Filter.
 6. The 16/12, 16/15, and 16/19 models are available as an at grade unit. This allows burial to a nominal 12-inch vertical exposure with an integrated airlift on the effluent outlet end of the Bioclere which will return the effluent to within 12 inches of finished grade.
 7. For Bioclere™ Modified Trickling Filter pretreatment systems that do not require a final pump dosing tank to the drainfield, an effluent filter in a basin/chamber will be placed on the outlet/discharge line from the Bioclere. The effluent filter shall have a maximum screening size opening of 1/16 of an inch.
 8. In addition to the general components provided by the manufacturer with each Bioclere™ Modified Trickling Filter, the layout of the system shall follow the "NC General Flow Schematic" (Attachment B). The following North Carolina-specific specifications shall be applicable to all approved units:
 - a. The flange connection joining the Bioclere filter section to the Bioclere sump section shall be factory sealed to provide a permanent watertight seal.
 - b. The internal shipping supports shall be removed, made from, or encapsulated with non-biodegradable material.
 - c. Each unit shall have a ventilation fan, a single dosing pump, a sludge return pump, and a low level float switch. With the exception of the 16 Series, the ventilation fan shall be rated at 115v/1ph/60hz, painted metal, ball bearing fan with a factory rated airflow of 240 cubic feet per minute. The 16 Series ventilation fan has a factory rated airflow of 58 cubic feet per minute.
 - d. For systems with a design daily flow greater than 3,000 gpd or that are treating high strength wastewater, dual dosing pumps will be required in the Bioclere™ Modified Trickling Filter.
 - e. The junction box for each Bioclere™ Modified Trickling Filter shall be a NEMA 4X enclosure.
 - f. Pump run timers for each pump shall be provided.
 - g. The AquaPoint control panel shall be connected to an active phone line, wireless internet router, dedicated cellular line, or other form of telemetry that notifies the operator authorized in writing by AquaPoint (authorized operator) of any alarm condition.
 9. General attributes of the approved Bioclere™ Modified Trickling Filter models are summarized in Table 1, below:

Table 1 - Bioclere™ Modified Trickling Filter Model Chart

Bioclere Model Number	Diameter (feet)	Vertical Size (feet)
16/12-SS	5' 2"	8' 7"
16/12-LS	5' 2"	9' 0"
16/15	5' 2"	10' 4"
16/19	5' 2"	11' 7"
16/22	5' 2"	12' 10"
16/25	5' 2"	14' 2"
24/12-950	8' 0"	12' 7"
24/12-1600	8' 0"	14' 1"
24/20-950	8' 0"	14' 8"
24/20-1600	8' 0"	16' 3"
24/24-950	8' 0"	16' 5"
24/24-1600	8' 0"	17' 11"
24/30-950	8' 0"	17' 8"
24/30-1600	8' 0"	19' 3"
30/12	10' 2"	14' 11"
30/24	10' 2"	17' 11"
30/32	10' 2"	20' 7"
36/20	12' 0"	17' 3"
36/24	12' 0"	19' 8"
36/30	12' 0"	21' 11"

Design Daily Flow (gpd)	Minimum Septic Tank Volume (gallons)	Bioclere Model Number for NSF/ANSI 40	Bioclere Model Number for TS-I	Bioclere Model Number for TS-II
Up to 360	1,500	16/12-SS	16/12-SS	16/12-SS
361 to 480	1,500	16/12-SS	16/15	16/15
481 to 600	1,500	16/12-SS	16/19	16/19
601 to 840	1,500	16/15	16/22	16/22
841 to 960	1,500	16/15	16/25	16/25
961 to 1,440	2,000	16/19	2 – 16/19	2 – 16/19
1,441 to 2,280	2,500	16/22	2 – 16/22	2 – 16/22
2,281 to 3,000	3,000	16/25	2 – 16/25	2 – 16/25

10. The 7-day and 30-day flow monitoring requirements will be met by one of the following options:
 - a. when an approved drip dispersal system is used, the flow monitoring requirements will be met by the drip system control panel,
 - b. when a drip dispersal system is used but only one control panel will be utilized, the Operator in Responsible Charge (ORC) will be provided with a Lascar USB Data Logger

- which will log effluent pump cycles and dosing time, or
- c. for systems with gravity or siphon dosed systems, a water meter (pulse generator) will be supplied to be installed on the water line serving the property and the Lascar USB Data Logger will be used to collect the flow data.
11. AquaPoint.3, LLC will provide authorized ORCs (contracted or employee) with a Lascar USB Data Logger for deployment on systems requiring its use.
 - a. The ORCs will be trained on the following: proper connection procedures, the procedure for collecting information, and printing out reports.
 - b. The ORC will deploy the unit at least 30 days prior to an annual required sampling and site inspection.
 - c. AquaPoint.3, LLC may also require it's ORC to visit a site weekly the month prior to the required sampling and site inspection visit for the purposes of obtaining flow readings.
 - d. Approved ORCs not employed by or under contract with AquaPoint.3, LLC may purchase the Lascar USB Data Logger and AquaPoint.3, LLC will provide the training and operation information.
 12. The UV disinfection system (optional for TS-I, required for TS-II) will be one of the following:
 - a. 0-1,500 gpd: "UV The Disinfecto[®]" or Salcor 3G unit.
 - b. 1,501-3,000 gpd: Dual bulb "UV The Disinfecto[®]" or Salcor 3G (2 units).
 - c. Other UV systems specifically approved by the Department and AquaPoint.3, LLC.
 13. Influent from each Bioclere[™] Modified Trickling Filter pretreatment system will be sampled by pulling an influent sample from the influent tee of the primary septic tank. The influent tee will extend to 50% of the tank depth. This arrangement will create an effective stilling well for raw influent wastewater. Effluent samples will be taken from the final pump tank downstream of the treatment system.
 14. Buoyancy calculations shall be completed by a North Carolina Professional Engineer (PE) for all Bioclere[™] Modified Trickling Filter pretreatment systems, associated tankage, and/or UV basins if they intersect the seasonal high-water table. Ballast shall be provided as necessary.
- B. Bioclere[™] Modified Trickling Filter systems treating waste streams other than domestic strength or domestic strength with design daily flows equal to or greater than 1,000 gpd shall be designed by a PE. Single family residential applications with a design daily flow less than 1,000 gpd shall be designed by a PE or a designer authorized in writing by AquaPoint (authorized designed).

VII. Installation and Testing

- A. A preconstruction conference shall be required to be attended by the authorized designer, PE, if required, AquaPoint manufacturer's representative, installer authorized in writing by AquaPoint (authorized installer), and local health department (LHD), prior to beginning installation of the Bioclere[™] Modified Trickling Filter pretreatment system.
- B. All Bioclere[™] Modified Trickling Filter pretreatment systems shall be installed according to directions provided by AquaPoint.
- C. All individuals or companies installing Bioclere[™] Modified Trickling Filter pretreatment systems shall be in possession of all necessary permits and licenses before attempting any portion of a

new or repair installation. The company/individual must be a Level IV installer and authorized installer.

- D. Watertightness of the tanks shall be demonstrated by a 24-hour leakage test conducted at the installation site after being installed and prior to backfilling. A water level change of ½ inch or more within a 24-inch riser over 24 hours, or visual observation of leakage shall be cause for failure of the watertightness test. Initial water level shall be 2 inches above the riser/adaptor seam.
- E. The top of the Bioclere unit shall be constructed to extend at least twelve inches above the ground surface and the surrounding area graded to shed surface water away from the containment structure. If the top is greater than 48 inches above the ground surface, OSHA approved access and rails shall be provided as approved by the project engineer.
- F. The authorized installer, PE or authorized designer, and the operator authorized in writing by AquaPoint (authorized operator), shall conduct a final inspection and start-up of the Bioclere™ Modified Trickling Filter pretreatment system and all associated components. The LHD will attend and observe the final inspection and start-up. The Bioclere Field Report in Attachment D shall be used during the final inspection and start-up.
- G. Specified site preparation steps and construction specifications for the dispersal system shall be strictly adhered to, including specified depth of trenches in relation to site limiting conditions, cover material specifications (if needed), trench installation method, etc.

VIII. Operation, Maintenance, Monitoring, and Reporting

- A. Bioclere™ Modified Trickling Filter pretreatment systems shall be classified, at a minimum, as a Type Va system in accordance with 15A NCAC 18E .1301(b), Table XXXII. Management and inspection shall be in accordance with 15A NCAC 18E, Section .1300.
- B. All Bioclere™ Modified Trickling Filter pretreatment systems require an operation and maintenance agreement between the system owner and AquaPoint, its authorized representative, or with an authorized operator in accordance with 15A NCAC 18E .1302(c). The authorized operator must have the proper equipment and training to access and program the control panels on site. The authorized operator shall be:
 - 1. a North Carolina certified subsurface operator (Operator in Responsible Charge); and
 - 2. either an employee of AquaPoint or authorized in writing by AquaPoint.
- C. All Bioclere™ Modified Trickling Filter pretreatment systems shall be operated and maintained according to the latest version of the AquaPoint's O&M manual.
- D. At each Bioclere™ Modified Trickling Filter pretreatment system inspection, the authorized operator shall follow service produced steps identified in the AquaPoint O&M Manual and, at a minimum, observe, monitor, and record the following:
 - 1. Wastewater level in all the tanks;
 - 2. Sludge and scum levels in all the tanks;

3. Clogging of effluent filter;
 4. Watertightness of tanks, risers, and pipe connections at the tanks;
 5. Operation of pumps, floats, valves, electrical controls, and alarms;
 6. Pumping frequency from pump impulse counters and elapsed run time meters;
 7. Dispersal field pump delivery rate (drawdown test), determination of the average pump run time, and dispersal field dosing volume;
 8. Any structural damage, accessibility issues, adequate ventilation, excess odors, ponding of effluent, insect infestations, vegetative growth over the dispersal field, or surfacing of effluent on the dispersal field area;
 9. Sample of Bioclere system effluent collected from the sampling point to check for effluent clarity, odor, and compliance with effluent standards;
 10. Readings from pump cycle counters and run time meters and any water meter readings, as applicable; and
 11. System operating conditions, from the review of stored data for flow variances or other abnormal conditions.
- E. The authorized operator shall conduct any other measurements, monitoring, maintenance activities, and observations as specified in the Operation Permit (OP) and recommended by the manufacturer.
- F. Sampling
1. All sampling shall be done in accordance with 15A NCAC 18E .1302 and .1709. Bioclere™ Modified Trickling Filter pretreatment systems shall be sampled annually when the design daily flow is less than or equal to 1,500 gpd. Systems with a design daily flow greater than 1,501 gpd and less than or equal to 3,000 gpd shall be sampled twice a year.
 2. Effluent for all systems shall be tested for effluent CBOD₅ and NH₄-N. Systems specified to meet the TS-II standard shall also have the effluent analyzed for TN (TKN and NO₃-N). Sampling is not required for fecal coliforms when the site is found to be compliant with all other constituents in Table XXV of 15A NCAC 18E .1201(a).
 3. Effluent samples shall be taken from the pump tank downstream of the treatment system.
 4. Influent samples, if needed, shall be taken from the influent tee of the primary septic tank. The influent tee extends down to 50% of the tank depth.
- G. Notification and Performance of Maintenance and Repairs
1. The authorized operator shall alert AquaPoint, the LHD, and the system owner within 48 hours of needed maintenance or repair activities including, but not limited to, landscaping, tank sealing, tank pumping, pipe or control system repairs, media replacement, and/or adjustments to any other system component.
 2. The authorized operator shall notify the system owner, AquaPoint, and the LHD whenever the pump delivery rate efficiency or average pump run times are not within 25 percent of the initial measurements taken during the system start-up.
 3. System troubleshooting and needed maintenance shall be provided to maintain the pump delivery rate and average pump run time within 25 percent of initial measurements conducted during system start-up.
 4. The septic tank will be pumped as needed upon recommendation of the authorized operator and in accordance with the Bioclere Operation and Maintenance Instructions. At a

minimum, the septic tank will be pumped whenever the scum and sludge levels combined is more than one-third depth in any compartment.

5. The tanks shall be pumped by a permitted septage management firm, and the septage handled in accordance with 15A NCAC 13B .0800.
6. All maintenance activities shall be recorded in the authorized operator reports provided to the system owner, LHD, and AquaPoint.

H. Reporting

The authorized operator shall provide a written report to the system owner, AquaPoint, and the LHD within 30 days of each inspection. At a minimum, this report shall specify:

1. The date and time of inspection;
2. System operating conditions according to VI.E, VI.E, and VI.F;
3. Results from laboratory analyses of any influent and effluent samples;
4. Maintenance activities performed since the last inspection report;
5. An assessment of overall system performance;
6. A list of any improvements or maintenance needed;
7. A determination of whether the system is malfunctioning, and the specific nature of the malfunction;
8. Any changes made in system settings, based on recommendations of the manufacturer,
9. A summary report of data retrieved from the control panel, including flow variances and other operating conditions; and
10. The completed Bioclere Field Report.

IX. Responsibilities and Permitting

- A. Prior to the installation of a Bioclere™ Modified Trickling Filter pretreatment system at a site, the owner shall submit an application or Notice of Intent (NOI) to the LHD for the proposed use of this system. Improvement Permits (IP) or Construction Authorizations (CA) issued by the LHD shall have a soil and site evaluation conducted either by the LHD, LSS, or Authorized On-Site Wastewater Evaluator (AOWE). The NOI shall include a soil and site evaluation conducted by an LSS.
- B. The IP, CA, and NOI shall contain all the conditions the site approval is based upon, including the proposed use of the Innovative system. The OP will include all conditions specified in the IP and CA. The Authorization to Operate (ATO) should include all the conditions specified in the NOI.
- C. When a special site evaluation is required pursuant to 15A NCA 18E .0510, an evaluation and written, sealed report from a Licensed Soil Scientist (LSS) regarding the site shall be provided to the LHD. The report shall contain the information specified in 15A NCAC 18E .0510(d). The LHD may request the assistance of their Regional Soil Scientist in evaluating this report prior to permit issuance.
- D. Bioclere™ Modified Trickling Filter pretreatment systems shall be designed by either an authorized designer, AOWE, or PE. Systems greater than 1,000 gpd, or as otherwise required for drip irrigation systems, shall be designed by a PE.

- E. Prior to the LHD issuing a CA for a Bioclere™ Modified Trickling Filter pretreatment system, a design submittal prepared by an authorized designer, AOWE, or PE shall be submitted. The design submittal shall include the information required in 15A NCAC 18E .0305.
- F. It is recommended that local authorized environmental health practitioners attend a design training session offered by the manufacturer or the authorized representative prior to permitting the system. Also, at the request of the LHD, a Regional Engineer will review the design.
- G. For sites required to be evaluated by an LSS or Licensed Geologist (LG), see Section V and IX.C, the LHD, AOWE, or PE may specify as a condition of the IP and CA that an LSS or LG oversee critical phases of the dispersal field installation and certify in writing that the installation was in accordance with their specified site and installation requirements prior to the OP or ATO issuance.
- H. The authorized ORC shall be present during the final inspection of the system prior to the issuance of the OP or ATO.
- I. The LHD shall issue the OP after the following:
 - 1. Field verification of installation completion;
 - 2. Receipt of written documentation from the authorized design, AOWE, or PE that the system has been designed, installed, and is operating in accordance with the approved plans; and
 - 3. All necessary legal documents have been completed, including the contract between the system owner and the authorized operator.

The LHD shall issue the OP for an (a2) and (a5) application after all necessary legal documents have been completed, including the contract between the system owner and the authorized operator.

The ATO shall be submitted to the LHD in accordance with G.S. 130A-336.1 and G.S. 130A-336.2.

X. Repair of Systems

The provisions of 15A NCAC 18E .1306 shall govern the use of Bioclere™ Modified Trickling Filter pretreatment system for repairs to existing malfunctioning wastewater systems.

Approved by: _____ Date: _____

Attachment A. Design Certification Letter



DESIGN CERTIFICATION

Day of Week, Month Day, Year

I. M. Engineer, PE
Engineer & Associates
100 E Main St
PO Box 100
Anywhere, US 12345

SAMPLE

Re: Proposed Project

This will certify that Aquapoint Inc.'s wastewater treatment equipment for the referenced project and as shown on the site plans *project name & location*, Final Revision *date*, prepared by *Engineer & Associates*, has been designed in accordance with generally accepted principles for the design of wastewater treatment systems. The system has been designed to meet the following specifications when installed in compliance with the approved plans and operated and maintained according to the manufacturer's recommendations.

If the maximum seasonal groundwater elevation is above the bottom of the Bioclere unit the resultant uplift forces may require concrete ballast surround of the Bioclere unit to offset buoyancy.

Design Specifications

FLOW	Q (GPD)		INFLUENT (MG/L)	EFFLUENT (MG/L)
Design	16,000	PH	6.5 – 8.5	6.5 – 8.5
Average	13,300	Temperature (degrees)	Min. 10 C	
Peak	16,000	BOD ₅	240	<10
		TSS	200	<10
		TKN	31.5	
		Ammonia Nitrogen		<10
		Total Nitrogen	37.5	<20 or 60% reduction

Attachment A. Design Certification Letter

This certification reflects the design parameters as indicated above and assumes no other environmental factors that will adversely affect treatment. Toxic products such as floor strippers, cleaners, degreasers and sanitizing products containing Quaternary Ammonium Chlorides (QAC's) are known to be highly toxic to the wastewater treatment system bacteria and should not be discharged to the wastewater system.

Material modifications to the referenced plans may affect this Certification. Aquapoint Inc. reserves the right to review the final approved plans and to modify this Certification accordingly.

Sincerely,

SAMPLE

Mark Lubbers
Aquapoint Inc.

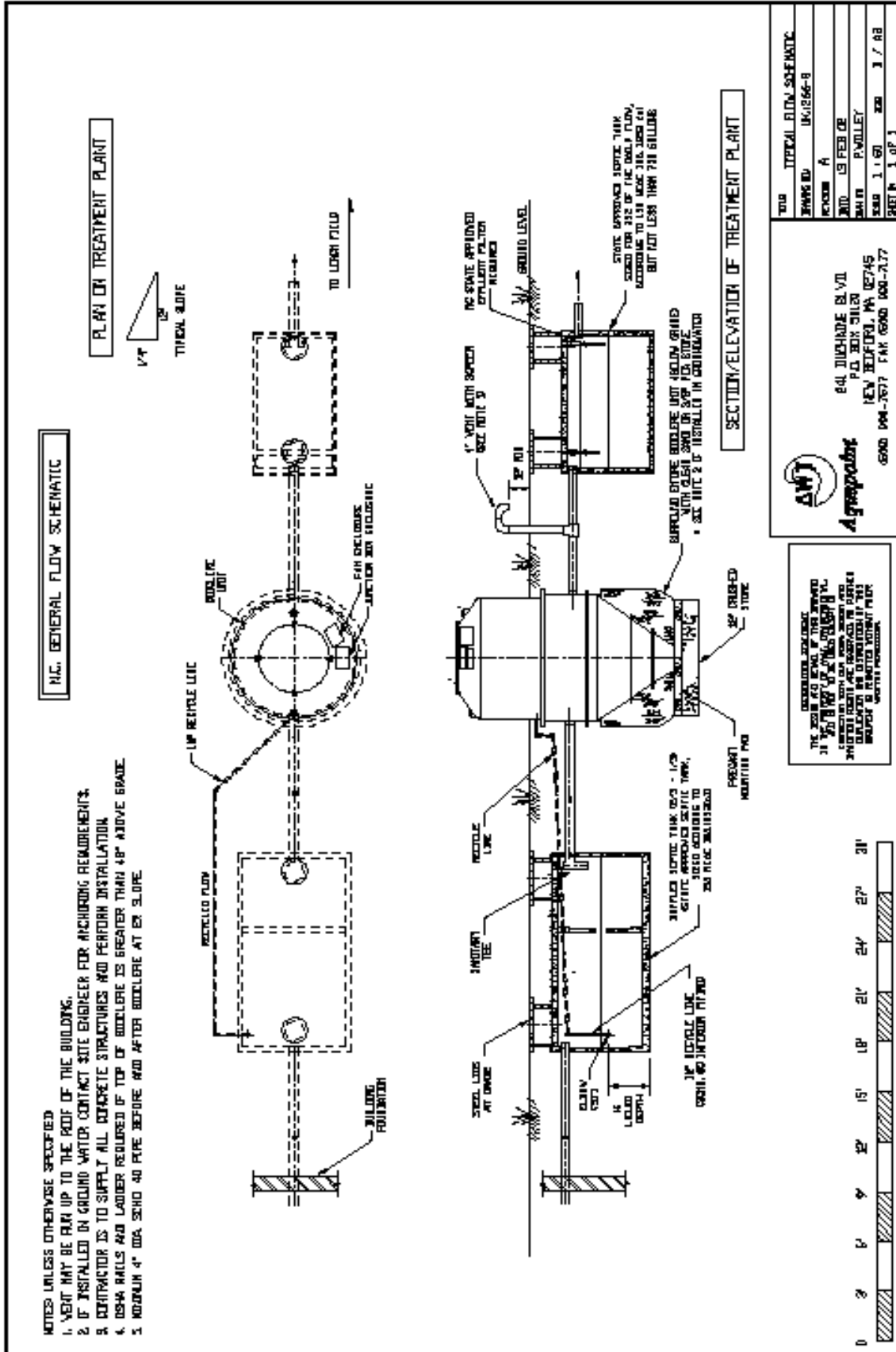

Attachment C. Bioclere Specifications

BIOCLERE SPECIFICATION

General

There shall be furnished and installed a factory built, fixed film aerobic process type sewage treatment plant(s) with all needed equipment for efficient operation. The unit shall include a trickling filter situated over a final settling tank.

Construction

The unit shall be delivered complete from supplier and shall include: random packed PVC manufactured media, ventilation fan, dosing pump(s), sludge return pump, internal piping, wiring and controls. The trickling filter portion of the tank shall have fiberglass inner and outer skins with the cavity between filled with polyurethane foam insulation. The remainder of the plant shall be constructed of FRP or plastic. All internal piping shall be schedule 40 PVC plastic pipe. The treatment plant shall withstand normal pressures from the interior hydrostatic load and from the soil.

The flange connection joining the Bioclere filter section to the Bioclere sump section shall be factory sealed with fiber reinforced plastic (FRP) to provide a permanent watertight seal.

The internal shipping supports shall be removed, made from, or encapsulated with non-biodegradable material.

The Bioclere units shall be leak tested for zero percent 24-hour leakage by filling the clarifier with clean water to the outlet invert.

Filter Media

The PVC randomly packed filter media has a void ratio of >95%. It is UV resistant and resistant to a wide range of aqueous solutions, acids, alkalis, oxidizing agents, oils, fats, and alcohols.

Final Settling Tank

A cone shaped settling tank shall have 60 degree sloped sides to prevent the accumulation of biological and inorganic suspended solids and shall contain the necessary internal baffling to prohibit short-circuiting of the wastewater.

Electrical Components

The unit shall have a ventilation fan, one media dosing pump for 16 series and two media dosing pumps for all others, a sludge return pump, and a low level float switch with the following characteristics.

The ventilation fan shall be a 115v/1ph/60hz, painted metal, ball bearing fan with a factory rated airflow rate 58 cubic feet per minute in 16 Series units, all other units fans will be 240 cubic feet per minute.

Dosing pumps and recycle pump shall be 115v/1ph/60hz stainless steel submersible pumps. All pumps shall have an internal high temperature shut off switch. The alternating dosing pumps shall be controlled such that when one pump fails the remaining operational pump will complete both dosing cycles.

The low level 115v/1ph/60hz float switch shall be installed to prevent the recycle pump from operating when water levels are abnormally low in the Bioclere (i.e. during primary tank pumping).

Attachment C. Bioclere Specifications

Power Supply

The unit shall have a dedicated properly sized power supply.

Wiring

The electrical contractor shall complete the wiring between the Bioclere control panel and the terminal strip within the Bioclere fan module meeting all local, state, and federal codes.

All fittings, connections, etc. shall be weatherproof and water tight construction. Ground terminals are provided in both the main panel and the junction box for each unit. Each ground terminal shall be wired to an earth ground.

The junction box for the Bioclere unit shall be in a NEMA 4X enclosure.

Care shall be taken to match the wires between the control panel and the terminal strip within the Bioclere fan module located on each unit.

Control Panel

A control panel shall be furnished with an audio and visual alarm for pump failure and tripped circuit breaker conditions, an exterior alarm silence button, and an on/off/test power/alarm toggle switch. Within the NEMA 4X enclosure: pump timers, pump run timers for each pump (elapsed time meters), terminal strip, on/off/test switches, run lights, dosing pump alternator, circuit breakers and current sensors shall be provided.

Warranty

All equipment provided shall be warranted against defects in materials and workmanship for a period of one year from the date of installation.

Attachment C. Bioclere Specifications

Services Provided

Aquapoint.3, LLC or an approved manufacturer's representative shall provide the following services for each project: Note that all Bioclere unit(s) and ancillary equipment supplied by Aquapoint.3, LLC is to be installed by the certified and approved installer.

- Review the design criteria, size and provide specifications for the Aquapoint.3, LLC supplied equipment.
- Review and comment on the site-specific site plan prior to manufacturing.
- Provide a Technical Manual that includes and is not limited to installation instructions; equipment specifications and operation and maintenance procedures for the Aquapoint.3, LLC supplied equipment.
- Provide onsite technical assistance for the handling and positioning of the Bioclere unit(s) the day of installation.
- Return to the site for testing and/or commissioning of the Bioclere unit(s) upon substantial completion of site work by the installer (piping, electrical, grading, etc.). Aquapoint.3, LLC may install the randomly packed PVC media, Aquapoint.3, LLC employee or appointed representative will install pumps into the Bioclere unit(s), which will complete unit setup. Aquapoint.3, LLC or approved representative will be available to train the operator(s) and instruct the owner on Bioclere operation the day of commissioning/testing.
- Test and/or commission the ancillary equipment supplied by Aquapoint.3, LLC the day of Bioclere commissioning and/or testing.
- Remain accessible to the owner and/or operator for phone consultation.
- Be available for additional site visits or consultation.

Attachment D. Bioclere Field Report

AQUAPOINT.3, LLC 39 Tarkiln Place TEL. 508 998-7577 FAX. 508 998-7177		
BIOCLERE FIELD REPORT		
Date:	Installation:	Tested:
Client:	Service:	Commissioned:
Address:	Other:	Scheduled Maint.
Inspector:		
Bioclere Model Number(s)		
1) ODOR		
Is there an odor around site? Y / N Source of odor?		
Check all that apply:	Mild: Med: Strong:	Musty: Septic:
2) SAMPLES	Influent	Effluent
Take influent/effluent samples as required?	Y / N	Y / N
Please fax analytical results to Aquapoint for review.		
3) SLUDGE		
a) Measure sludge in primary tanks and grease traps as required:		
b) Primary tank:	Scum depth:	Sludge depth:
c) Does grease trap need pumping? Y / N	Scum depth:	Sludge depth:
4) BIOCLERE VENTS	UNIT 1	UNIT 2
a) Is air passing through the vent? If in doubt put a small plastic bag around the vent and allow to fill		Y / N
b) Is the fan operating and in good condition?	Y / N	Y / N
5) GENERAL		
a) Any external damage to the unit(s)? If yes, then provide details on back	Y / N	Y / N
b) Are cover, fan box and control panel securely locked?	Y / N	Y / N
c) Any filter flies in the unit?	Y / N few / many	Y / N few / many

Attachment D. Bioclere Field Report

Location of flies:		
d) Locks / Latches / Handles, OK?	Y / N	Y / N
e) Lid Gasket, OK?	Y / N	Y / N
f) Does the fan box contain standing water?	Y / N	Y / N
If yes, then remove water and clean drain holes if necessary.		
6) BIOMASS CHARACTERIZATION		
a) Color of biomass?		
1)white 2)white/grey 3)grey 4)grey/brown 5)brown 6)red/brown 7)black 8)other		
b) Thickness of biomass 6- 12 inches below media surface		
1) light 2) medium 3) heavy		
7) NOZZLE SPRAY PATTERN		
a) Does spray cover the entire surface of media?	Y / N	Y / N
If not then clean each nozzle with a bottle brush		
Does the spray now cover the entire surface area?	Y / N	Y / N
If not then:		
1) remove nozzles and soak them in a bleach solution		
2) manually engage both dosing pumps for 2 minutes		
3) replace nozzles		
Does the spray now cover the entire surface area?	Y / N	Y / N
If not then consult Aquapoint , Inc.		
8) PUMPS AND CONTROL PANEL		
a) Record dosing and recycle pump timer settings from control panel		
Dosing pump 1 and 2:	Min on/ min off	Min on/ min off
Recycle pump:	Min on/ min off	Min on/ min off
In Bioclere control panel set dosing and recycle timers to a test cycle:		
a) Measure amperage of dosing pump 1:	amps	amps
b) Measure amperage of dosing pump 2:	amps	amps
c) Measure amperage of dosing pump:	amps	amps
Are the dosing pumps alternating?	Y / N	Y / N
Are the timers operating properly?	Y / N	Y / N

Attachment D. Bioclere Field Report

Visually inspect relays for wear and record problems below.		
*If spare components are needed contact Aquapoint		
If an ammeter is not available, set the timers to a test cycle as above and		
physically at the Bioclere, check the pumps operation as follows:		
Dosing pumps: Check that pump(s) are operating, alternating and the designated rest cycle is occurring.	Pump 1: OK? Y/ N	Pump 1: OK? Y/ N
Recycle pump(s): check that pump(s) are operating, and the designated rest cycle is occurring.	Pump 2: OK? Y/ N	Pump 2: OK? Y/ N
	OK? Y/ N	OK? Y/ N
*If pumps or control components are not operating properly record below and consult Aquapoint, Inc.		
RESET TIMERS TO ABOVE SETTINGS: Note any changes here:	Min on/ min off	Min on/ min off
* Do not change timers without consulting Aquapoint	Min on/ hrs off	Min on/ hrs off
9) PLUMBING		
a) Are the unions in the Bioclere leaking? If yes then tighten with pipe wrench	Y / N	Y / N
10) FINAL CHECK		
a) Main power "on" and toggle for all pumps set to "normal" position	Y / N	Y / N
b) Alarm toggle set to the "on" position	Y / N	Y / N
c) Lock control panel, Bioclere cover and fan box		
d) If possible, record the water meter reading:		

11) REPORT SUMMARY:

Attachment D. Bioclere Field Report

SIGNATURE:

DRAFT